

KILCOY COW HORSE CLUB STOCKMANS CHALLENGE: RD 3 ENCOURAGEMENT WORKING PATTERN

RIDER NAME: _____

HORSE NAME: _____

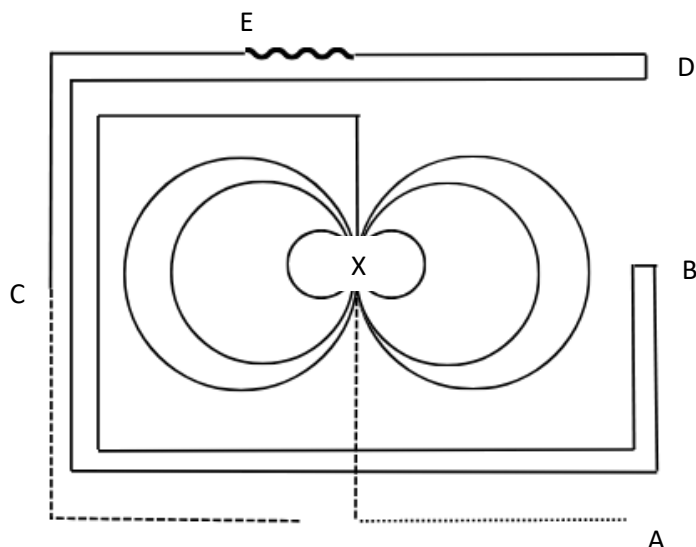

		Possible Points	Judge's Marks
1	Type, Presentation and Overall Impression	10	
2	Enter arena at A on a loose rein, walk to Judge and acknowledge Judge. Sit trot to X	10	
3	Do 1 spin to the right, do 1 spin to the left	10	
4	Sit trot medium circle to the right, canter large circle to the right	10	
5	Do a simple change at X, canter large circle to the left, rise trot medium circle to the left	10	
6	At X, do an extended canter to the left around to B, roll back right	10	
7	Extended canter around to D, roll back left	10	
8	Canter to E, stop, settle, rein back approx. 3 metres until in line with the Judge	10	
9	Sit trot to C on a loose rein	10	
10	From C, walk to Judge on a light rein	10	
Total		100	

CATTLE WORK SCORE	
--------------------------	--

